

Clarke® Auto Charge



6V/12V INTELLIGENT BATTERY CHARGER
MODEL NO: IBC8
PART NO: 6267035

OPERATION & MAINTENANCE INSTRUCTIONS



ORIGINAL INSTRUCTIONS

DL0721

INTRODUCTION

Thank you for purchasing this CLARKE Battery Charger.

Please read this manual thoroughly, before attempting to operate this product and carefully follow all instructions given.

It is vitally important that **ALL** precautions are taken, as specified, which will not only provide protection for yourself and that of others around you, but will also ensure that the battery charger will give you long and satisfactory service.

GUARANTEE

This CLARKE product is guaranteed against faulty manufacture for a period of 12 months from the date of purchase. Please keep your receipt as proof of purchase.

This guarantee is invalid if the product is found to have been abused or tampered with in any way, or not used for the purpose for which it was intended.

Faulty goods should be returned to their place of purchase, no product can be returned to us without prior permission.

This guarantee does not effect your statutory rights.

ENVIRONMENTAL RECYCLING POLICY









Through purchase of this product, the customer is taking on the obligation to deal with the WEEE in accordance with the WEEE regulations in relation to the treatment, recycling & recovery and environmentally sound disposal of the WEEE.

In effect, this means that this product must not be disposed of with general household waste. It must be disposed of according to the laws governing Waste Electrical and Electronic Equipment (WEEE) at a recognised disposal facility.

SPECIFICATIONS

Model Number	IBC8
Input voltage / Current	230V, 50Hz
Battery charging voltages:	6V & 12V
Power	320W Max
Output current	6V: 4A 12V:8A
Charging steps	9 steps, (smart charger)
Charging Battery Capacity	160 AH
IP Rating	IP40
Operating Temperature Range	-20 to 50°C
Dimensions (D x W x H)	167mm x 135mm x 65mm
Power Cable Length	1.80m
Charging Clamp Cable Length	1.80m
Ring Terminal Cable Length	1.80m
Weight	1.1 kg

SAFETY SYMBOLS

	Before Use, Read The Instructions Fully		For Indoor Use Only
	Class II Appliance		Wear Eye Protection
	Wear a Protective Mask		Wear Protective Gloves

OVERVIEW

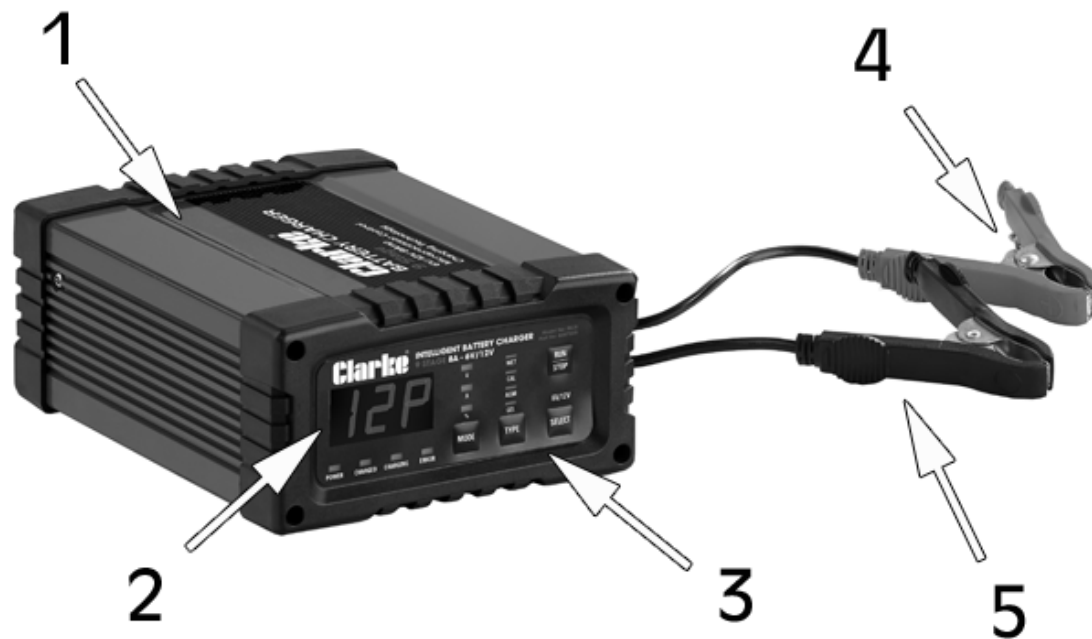

1	Battery Charger Unit	4	Charging Clamp Positive (Red)
2	LCD Display Screen	5	Charging Clamp Negative (Black)
3	Control Buttons		

The IBC8 is designed for charging most types of 6V & 12V lead-acid, GEL, MF (Maintenance Free), Calcium and AGM (Absorbed Glass Mat) batteries.

DO NOT use this product to charge other type of batteries like Nickel Cadmium (NiCad), Nickel-Metal Hydride (Ni-MH), Lithium-Ion, Dry Cell etc.

ELECTRICAL CONNECTIONS



WARNING! READ THESE ELECTRICAL SAFETY INSTRUCTIONS THOROUGHLY BEFORE CONNECTING THE PRODUCT TO THE MAINS SUPPLY.

Before switching the product on, make sure that the voltage of your electricity supply is the same as that indicated on the rating plate. This product is designed to operate on 230VAC 50Hz. Connecting it to any other power source may cause damage.

This product may be fitted with a non-rewireable plug. If it is necessary to change the fuse in the plug, the fuse cover must be refitted. If the fuse cover becomes lost or damaged, the plug must not be used until a suitable replacement is obtained.

If the plug has to be changed because it is not suitable for your socket, or due to damage, it should be cut off and a replacement fitted, following the wiring instructions shown below. The old plug must be disposed of safely, as insertion into a mains socket could cause an electrical hazard.

If the colours of the wires in the power cable of this product do not correspond with the markings on the terminals of your plug, proceed as follows.

- The **Blue** wire must be connected to the terminal marked **N** or coloured **Black**.
- The **Brown** wire must be connected to the terminal marked **L** or coloured **Red**.

Plug must be BS1363/A approved.

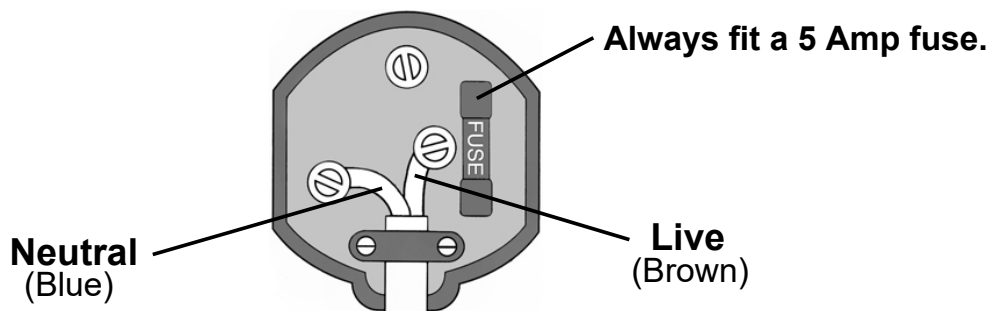

Ensure that the outer sheath of the cable is firmly held by the clamp

We strongly recommend that this machine is connected to the mains supply via a Residual Current Device (RCD)

If in any doubt, consult a qualified electrician. **DO NOT** attempt any repairs yourself.



This symbol indicates that this is a Class II product and does not require an earth connection.

SAFETY PRECAUTIONS



WARNING: ALWAYS SWITCH OFF THE CHARGER WHEN CONNECTING OR DISCONNECTING LEADS TO AVOID SPARKING AS HIGHLY INFLAMMABLE HYDROGEN GAS CAN BE RELEASED IN THE PROCESS OF BATTERY CHARGING

PLEASE READ BEFORE USING THIS UNIT

1. Batteries can generate explosive gases during normal operation. **ALWAYS** use in well ventilated area.
2. **DO NOT** smoke, strike a match or cause a spark in the vicinity of the battery or engine. Avoid explosive gas, flames and sparks.
3. Remove all personal jewellery, such as rings, bracelets, necklaces and watches while working with a vehicle battery. These items may produce a short circuit and could cause severe burns.
4. Be extra cautious to reduce the risk of dropping a metal tool onto the battery. It may spark or short circuit the battery or other electrical hardware which may cause an explosion or fire.
5. Wear complete eye protection, hand and clothing protection. **AVOID** touching eyes while working near a battery.
6. Study all battery manufacturers specific precautions, such as removing or not removing cell caps while charging and recommended rates of charge.
7. Clean battery terminals before connection with the charger. Be careful to keep corrosion from coming in to contact with eyes.
8. When it is necessary to remove the battery from the vehicle to charge, always remove grounded terminal from the battery first. Make sure all accessories in the vehicle are switched off in order to prevent an arc.
9. This charger is **NOT** intended to supply power to an extra low voltage electrical system or to charge dry cell batteries. Charging dry cell batteries may cause the battery to burst and cause injury to person or property.
10. **NEVER** charge a frozen, damaged, leaking or non rechargeable battery.
11. If battery electrolyte contacts skin or clothing, wash immediately with soap and water. If electrolyte enters your eye, immediately flood eye with running clean cold water for at least 15 minutes and seek medical attention immediately.
12. **DO NOT** place the charger in the engine compartment, near moving parts or near the battery. Place as far away from them as the cable permits.

NEVER place the charger directly above the battery being charged, gases or fluids from the battery will corrode and/or damage the charger.

13. **DO NOT** cover the charger while charging.
14. **DO NOT** expose to rain or wet conditions.
15. Connect and disconnect the DC output connections only after disconnecting the charger from the mains power supply.
16. Use of an attachment not recommended or sold by the manufacturer may result in a risk of fire, electric shock or injury to persons.
17. **DO NOT** overcharge batteries by selecting the wrong charge mode.
18. To reduce the risk of damage to the electric plug and cord, pull by the plug rather than the cord when disconnecting charger from mains power supply.
19. To reduce risk of electric shock, unplug charger from mains power supply before attempting any maintenance or cleaning.
20. Operate with caution if the charger has received a direct hit of force or been dropped. Have it checked and repaired if damaged.
21. **NEVER** attempt any repairs yourself. If you have a problem with your charger contact your local CLARKE dealer or contact service@clarkeinternational.com
22. When charging is complete, ensure that the vehicle battery leads are secured to the proper terminals which should be clean, and lightly smeared with petroleum jelly to prevent corrosion. Finally, re-check the electrolyte level.

PREPARATION

1. It may be necessary to remove the battery from a vehicle to charge it.
 - **ALWAYS** remove the grounded terminal from the battery first.
 - Ensure all accessories in the vehicle are switched off to prevent sparking.
2. Clean the battery terminals. Be careful to keep any corrosive matter from coming in contact with eyes. If corrosive matter enters your eye, immediately flood eye with running clean cold water for at least 15 minutes and seek medical attention immediately.
3. If the battery can be topped up, add distilled water to each cell until the battery acid reaches the level specified by the battery manufacturer. This helps remove unwanted gas from the cell. **DO NOT** overfill. For a battery without cell caps, follow the manufacturer's instructions.
4. Study all the battery manufacturer's specified precautions: for example, removing or not removing cell caps while being charged and recommended rates of charge.
5. Refer to the vehicle manual and battery rating plate to find the voltage of the battery and make sure that the output is set to the correct voltage.
6. If the charger has adjustable charge rate, charge the battery initially at the lowest rate.

CHARGER LOCATION

1. Place the charger as far away from the battery as possible.
2. **DO NOT** position the charger above the battery during the charging procedure. Gases from the battery may corrode and damage the charger.
3. **DO NOT** let battery acid drip on the charger when reading a hydrometer for specific gravity or when you fill the battery.
4. **DO NOT** use the charger in an enclosed space with reduced airflow.

CONTROLS

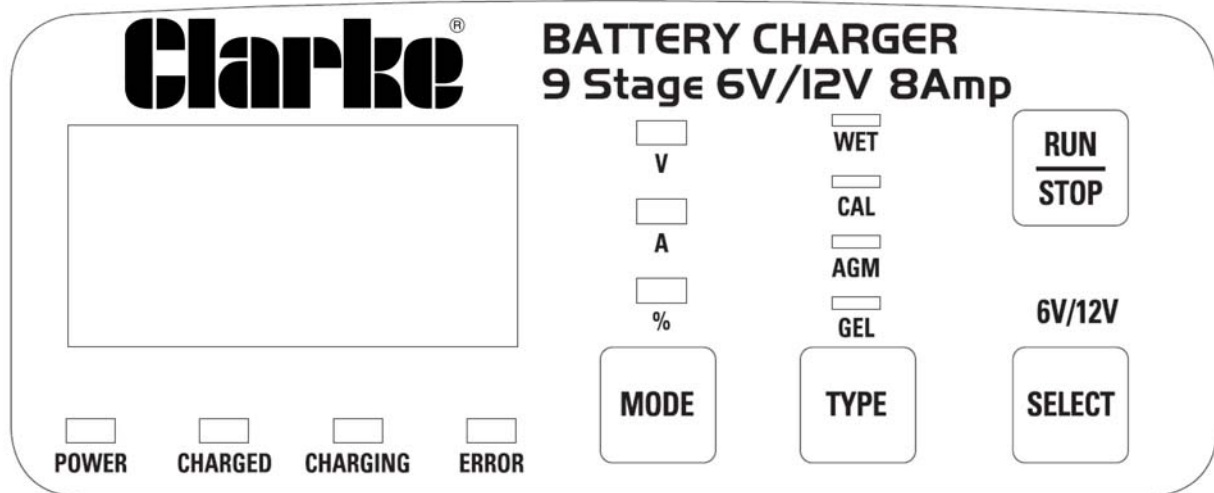

BATTERY CHARGE INDICATORS:

1. **Power** - A green LED illuminates to confirm power is being supplied to the battery charger. If it is the only LED illuminated, the charger is in "Maintain Mode".
2. **Charged** - A green LED illuminates to signal that the battery is fully charged and may be disconnected for use. If left "on charge", the LED will turn off after 1 hour and only the green power LED will stay illuminated.
3. **Charging** - An amber LED illuminated to signal that the charger is charging the battery.
4. **Error** - A red LED illuminates if the connection is wrong, the incorrect battery voltage is selected or the battery is faulty. In each of these instances, the charging of the battery will not proceed.

NOTE: The LCD will show Er1, if the clamps are "shorted", loose or poorly connected, if the battery voltage is less than 0.5V, or if the battery voltage is >15.5V (for 12V Mode) or >7.8V (for 6V Mode).

NOTE: The LCD will show Er2, if the battery is damaged or unable to be charged.

NOTE: The LCD will show Er4, if the clamps are connected incorrectly, i.e. reverse polarity (+ve clamp to -ve battery terminal and -ve clamp to +ve battery terminal).

NOTE: Batteries with a battery voltage below 10.5V may be permanently damaged. It is recommended that batteries not be discharged to below 10.5V.

MODE:

1. **V** - Displays the battery voltage prior to pressing RUN, and displays the actual charging voltage during each of the charging cycles.

NOTE: Due to the pulse voltages applied during the desulphation mode, the displayed voltage may constantly change and cycle from 0 volts to 16 volts.

2. **A** - Displays the current in Amps (A) being applied to the battery during charging.

NOTE: If 0.0 is displayed, a very small current (A) is being applied to achieve maximum charge.

3. **%** - Displays the charge condition of the battery as a percentage of full charge.

TYPE:

1. **WET** - Conventional automotive starting lead acid batteries generally have six cells, each containing lead plates and sulphuric acid. These batteries provide a high current output in short bursts and are ideally suited to automotive starting applications.
2. **CAL** - Calcium batteries are essentially the same as lead acid batteries. However, the addition of small amount of calcium to the lead plates means calcium batteries have low water loss, low self discharge characteristics, lower internal resistance which provides a small increase in CCA performance and a higher charge rate acceptance compared to standard lead acid batteries.
3. **AGM** - Absorbed Glass Mat batteries are a type of valve regulated lead acid battery designed to wick the battery electrolyte between the battery plates. AGM batteries contain only enough liquid to keep the mat wet with the electrolyte and if the battery is broken no free liquid is available to leak out. The advantages of this type is that the electrolyte does not need topping up, nor can it be. They can be operated in any position and they have a very low gas release during charging. these batteries are however, sensitive to overcharging and require a different charge algorithm than standard lead acid batteries.
4. **GEL** - GEL batteries are a type of valve regulated lead acid battery and are typically more costly and do not offer the same power capacity as AGM batteries of a similar size. The GEL cell battery excels in slow discharge rates and higher ambient operating temperatures. GEL cell batteries must be recharged correctly or the battery will suffer premature failure.

RUN/STOP

After selecting the above parameters pressing the RUN/STOP button starts and stops the charger. After commencing a charge cycle, use this button to stop the charger to change any of the charge parameters, e.g. current or chemistry. Recommence the charge cycle by pressing the button.

FEATURES

MICROPROCESSOR TECHNOLOGY

The latest technology in battery chargers converts 240VAC to DC charging power using electronic components, unlike traditional battery chargers that rely on large heavy transformers. This allows the charger to be lightweight and compact without sacrificing performance. To increase safety, polarity protection prevents the output leads from sparking due to accidental reverse connection or short circuit.

MAXIMISING BATTERY PERFORMANCE

Your battery will perform better when charged using a 9 stage charger, maximising the output from the battery.

MAXIMISE BATTERY LIFE

Batteries used regularly will last longer when charged using a 9 stage charger, saving you money on expensive batteries.

AUTOMATIC MICROPROCESSOR CONTROL

The charger can be left connected to the battery without risk of overcharging. Once the battery is full, the charger will automatically monitor the battery and top up the battery when required, ensuring it is always ready for use.

BATTERY CHEMISTRY SELECTION

The charger includes intelligent chemistry technology to provide the most suitable charge profile for the applicable chemistry.

- 1. WET (Lead Acid) - Bulk/Absorption 14.7V, Recondition 15.8V.** Conventional automotive "starting" batteries provide a high current for short periods and are ideally suited to automotive starting applications.
- 2. GEL/AGM - Maximum Voltage of 14.2V = GEL and 14.4V = AGM.** GEL and AGM batteries are types of valve regulated lead acid (VRLA) batteries and due to their design can be orientated in any position and exhibit very low gas release during charging. These batteries do not allow the replenishment of electrolyte levels and are sensitive to overcharging, requiring lower charge rates.
- 3. Calcium - Bulk Absorption 14.7V, Equalisation/Recondition 15.8V.** Calcium batteries are essentially the same as lead acid batteries, however the inclusion of calcium significantly reduces fluid loss, provides much lower self discharge characteristics and lowers internal resistance, which increase its cold cranking current (CCA) performance. To ensure optimal battery condition and to maintain a maximum state of charge, a special profile is

needed to balance cell voltages and/or remove unique sulphation barriers caused when calcium batteries have a high demand or are left discharged for a number of days.

ADJUSTABLE CHARGE VOLTAGE

The charger's output voltage (V) can be selected to suit the output voltage of the battery being charged, i.e. 6V or 12V.

LIQUID CRYSTAL DISPLAY (LCD) - VOLTAGE (V), CURRENT (A) & PERCENTAGE CHARGED (%)

The LCD provides three selectable display outputs. The LED indicators on the fascia highlight the selected characteristic being monitored and displayed.

DE-SULPHATION FUNCTION

This feature provides a stepped or pulsed voltage to help remove the sulphation of plates which can occur when batteries are left discharged for prolonged periods.

NOTE: If the battery is unable to be recovered (i.e. the sulphation of the plates is too severe), the battery charger will display the error message Er2.

RECONDITIONING

When the battery has been left unattended for a prolonged period, the sulphation of the plates may be severe for stage 2: De-sulphation cycle to adequately clean plates. In these instances, the ANALYSIS stage will identify that sulphation of the plates still exists and an additional RECONDITION stage will provide a more concerted effort in an attempt to recover the battery.

For calcium batteries, the RECONDITION stage will balance any differences in cell voltage, and repair cell stratification of the calcium battery.

NOTE: The inclusion of a RECONDITION stage may significantly increase the charge time (up to 48 hours).

LIQUID CRYSTAL DISPLAY

A liquid crystal display (LCD) provides a clear, easy to read display.

CELL EQUALISATION

The charger provides a low voltage PRE-CHARGE function at a low current to allow the battery cells to equalise.

OVER TEMPERATURE CONTROLS

When the internal temperature of the charger reaches 50c, sensors reduce the output current to minimise damage due to overheating.

NOTE: This feature may cause an increased charge time due to interruptions to the charge cycle.

AUTOMATIC MULTI-CYCLE CONDITIONING

If the battery will not hold a charge at the completion of the first cycle, the 9 stages of the cycle are automatically repeated for up to a further two times to achieve the battery's maximum charge condition. This minimises the need to monitor and repeat the charge cycle if the condition of the battery is not optimum after the first charge cycle.

NOTE: This feature may significantly increase the charge time (up to 48 hours).

OPERATION

PLACEMENT/MOUNTING

The charger is designed for indoor use only. The position selected for the charging of the battery must be cool, dry, clean and well ventilated, away from flammable goods and ignition sources.

NOTE: When utilised in caravans, motorhomes, 4WD's or similar, the charger should be placed or mounted in a well ventilated location and protected from rain, water or moisture at all times.

Connection to the mains supply must be in accordance with national wiring rules and regulations.

To minimise TV/Radio interference, position the charger well away from any TV, radio, antenna and antenna cables.

CHARGING INSTRUCTIONS

BATTERY MANUFACTURER RECOMMENDATIONS

Before using the battery charger, study the battery manufacturers recommendations, rates of charge and any particular conditions to the battery being charged.

CHECK THE ELECTROLYTE LEVEL

Prior to charging the battery, remove the vent caps and check the electrolyte level.

NOTE: For batteries without cell caps, follow the battery manufacturers maintenance and charging instructions.

CONNECTION

a. Connection with Battery out of the Vehicle

Connect the **POSITIVE (RED)** lead/battery clamp from the charger to the **POSITIVE** battery post. Connect the **NEGATIVE (BLACK)** lead/battery clamp from the charger to the **NEGATIVE** battery post.

NOTE: The **POSITIVE** terminal of a battery is defined by the colour **RED** and may be presented by **POS, P** or **(+)**. The **NEGATIVE** terminal of a battery is defined by the colour **BLACK** and may be represented by **NEG, N** or **(-)**.

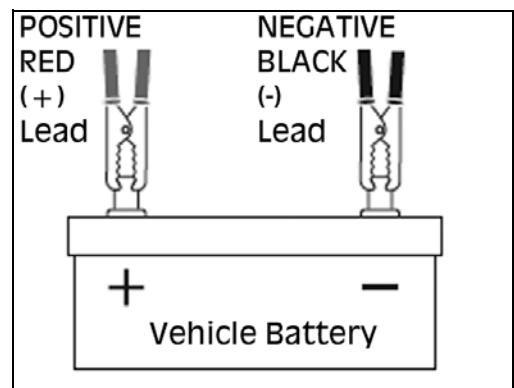

Wiggle or swivel the clamps several times - this action ensures integrity of the connection and minimises sparks/arcng.

b. Connection with the Battery Mounted in the Vehicle

Determine if the vehicle is **POSITIVELY (+)** or **NEGATIVELY (-)** earthed.

NOTE: The battery terminal **NOT** connected to the chassis **MUST** be connected to the battery charger first. The second clamp from the battery charger must be connected to the chassis away from the battery and fuel lines.

Refer to the following guides for correct battery clamp connection sequence:

Negatively Earthed (Most Vehicles)

NOTE: Negatively earthed vehicles usually have a cable (usually **BLACK** or **GREEN**) connecting the negative battery terminal to the vehicles chassis.

Connect the **POSITIVE (RED)** lead/battery clamp from the battery charger to the Positive (+) battery terminal. Connect the **NEGATIVE (BLACK)** lead/battery clamp from the battery charger to the vehicles chassis - away from the fuel lines or moving parts.

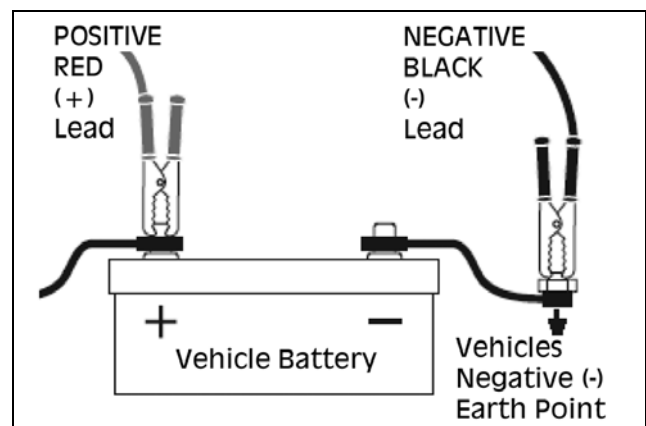

Positively Earthed

Connect the **NEGATIVE (BLACK)** lead/battery clamp from the battery charger to the Negative (-) battery terminal. Connect the **POSITIVE (RED)** lead/battery clamp from the battery charger to the vehicles chassis - away from the fuel lines or moving parts.

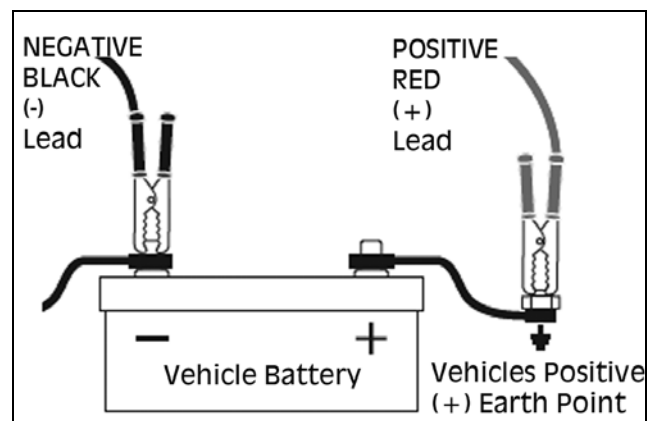

CONNECT TO MAINS POWER

Connect the battery charger to a 230V mains powered socket, turn on the mains power and press the "ON/OFF" button. The power LED and LCD will illuminate to confirm that the battery charger is receiving power.

SELECT THE CHARGE VOLTAGE

Press the "SELECT" button to select the appropriate battery voltage - 6V or 12V. The LCD will display 6P or 12P.

SELECT THE BATTERY CHEMISTRY

Press the "TYPE" button to select the appropriate battery chemistry and technology - WET, CALCIUM, AGM or GEL.

NOTE: If the battery charger does not detect a correctly connected battery, or detects an incorrect battery voltage, Er1 or Er4 code will display on the LCD and charging will not commence.

CHARGING

The CHARGING LED will illuminate and the voltage being supplied to the battery is displayed in the LCD window.

MONITORING

During charging cycles, voltage (V), current (A) or percentage charged (%) can be displayed on the LCD by pressing the "MODE" button. After approximately 5 seconds, the LCD display will revert to voltage (V).

NOTE: During the charge cycle, voltages up to 15.8V (7.9V in 6V mode) may be observed, this is deemed normal.

CHARGING COMPLETE

Once charging of the battery is complete, the charging LED will extinguish, the charged LED will illuminate and FUL will display in the LCD window for 2 minutes. At this point, the red LCD will extinguish and the green charged and power LED's will continue to illuminate to show that the battery is charged.

NOTE: If at any stage during charging, the battery is found to be faulty, Er2 will be displayed and charging will terminate.

Once charging is completed and FUL is displayed in the LCD window, **BEFORE** removing the battery clamps, press the ON/OFF button to turn the battery charger "OFF", switch the mains supply power to OFF and disconnect (Unplug) the battery charger from the supply socket outlet.

NOTE: If left "ON" and connected to main supply, the charger will monitor the battery and maintain the battery ready for use - preventing slow discharge over time, which is detrimental to lead acid batteries.

DISCONNECTION - BATTERY OUT OF THE VEHICLE

Remove the **NEGATIVE (BLACK)** connection first, then remove the **POSITIVE (RED)** terminal clamp.

DISCONNECTION - BATTERY MOUNTED IN THE VEHICLE

Remove the chassis connection first, then remove the other battery clamp from the battery terminal.

RECHECK THE ELECTROLYTE LEVELS

Recheck the electrolyte levels and top up if required - this is especially necessary for Calcium type batteries.

CARE & MAINTANENCE

This battery charger requires minimal maintenance. As with any appliance or tool, a few common sense rules will prolong its working life.



WARNING: ALWAYS BE SURE THE CHARGER IS UNPLUGGED BEFORE PERFORMING ANY MAINTENANCE OR CLEANING. ANY REPAIRS MUST BE DONE BY A QUALIFIED SERVICE TECHNICIAN.

1. Wind up the leads when not in use. Examine the leads at regular intervals for damage and have them replaced if necessary.

Clean the case and leads if necessary with a moist cloth and clean any corrosion from the clamps with a solution of water and baking soda.

PARTS DIAGRAM

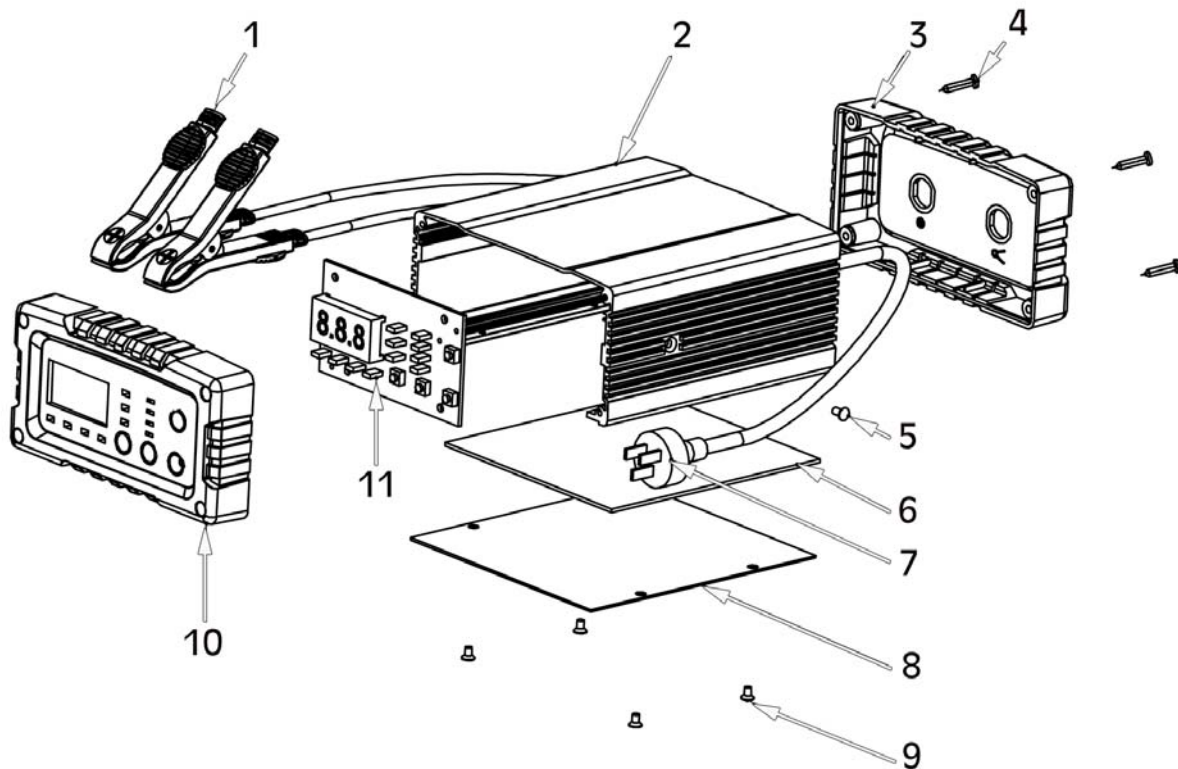

PARTS LIST

No	DESCRIPTION	No	DESCRIPTION
1	Charging Cables & Clamps	7	Power Cable
2	Aluminium Case	8	Bottom Case Panel
3	Back Panel	9	Screw, M3 x 5
4	Screws, ST3 x 10	10	Front Panel
5	Screws, M3 x 14	11	Display Board
6	Printed Circuit Board Assembly		

CHARGE CYCLES

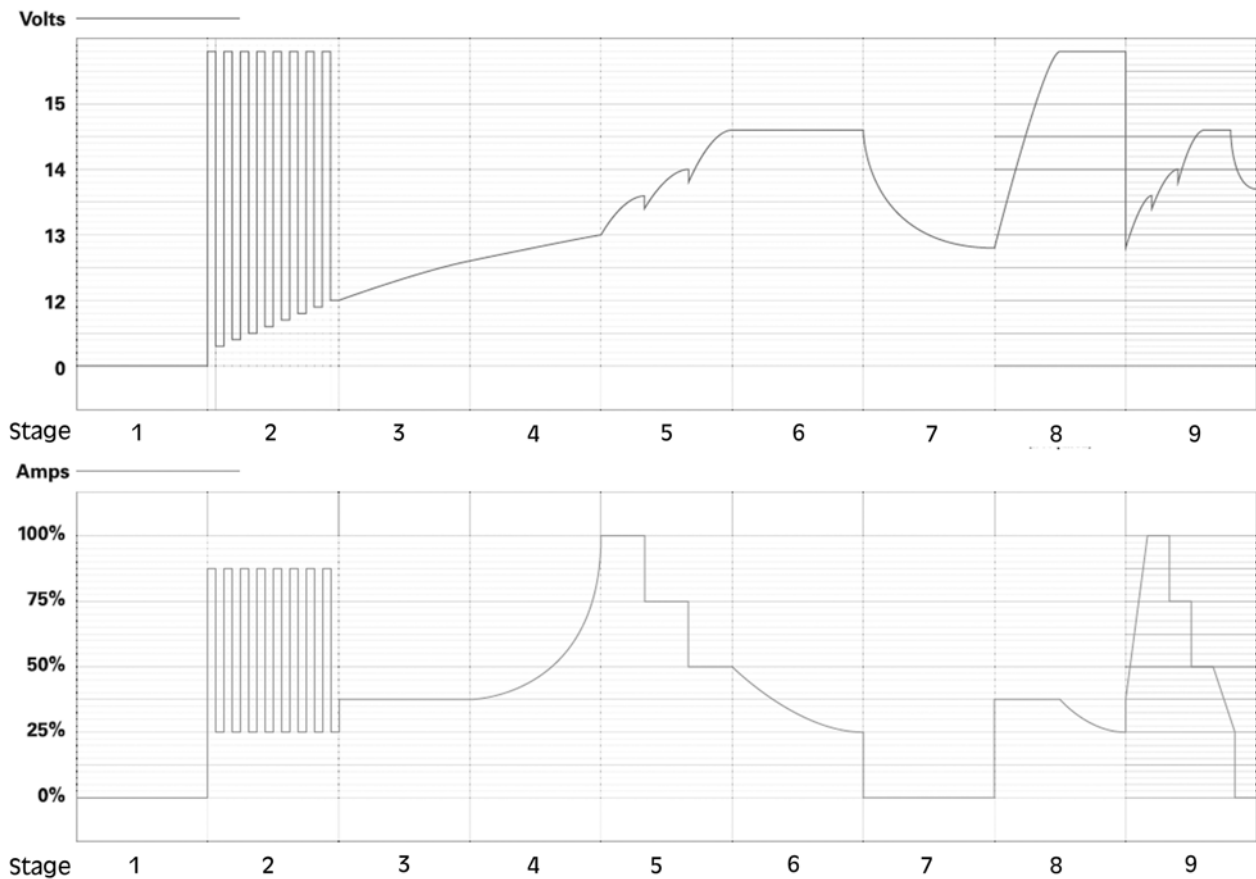

STAGE	FUNCTION	DESCRIPTION
1	Diagnosis	To determine whether the battery is defective. Charging will not proceed if the battery voltage is <math><0.5V</math> and an error code will be displayed on the LCD.
2	Desulphation	This stage provides a stepped or pulsed voltage to help remove the sulphation of plates which can occur when the battery is left discharged for prolonged periods. It also stabilises electrolytic balance and minimises excessive battery temperature.
3	Pre-Charge	A low voltage and current is used to slowly increase battery condition and further improve electrolytic consistency which can become uneven due to day to day use.
4	Soft Start	At an increased voltage, the current is slowly increased over time to control heat, reduce gassing and minimise battery stress.

STAGE	FUNCTION	DESCRIPTION
5	Bulk Charge (Constant Current)	Initially, maximum current is applied to the battery however, the three phases of the stage reduce the time to charge, control electrolytic loss and enhance battery health and life.
	CC1	CC1 - Charging at maximum current.
	CC2	CC2 - Current is reduced.
	CC3	CC3 - Current is further reduced for improved charge whilst minimising electrolyte loss and excess temperature.
6	Absorption (Constant Voltage)	Applying an even higher voltage whilst reducing current over time ensures the battery is topped up but not over charged
7	Analysis	The charger conducts an analysis of the battery over a period of time to determine the battery discharge rate. Based on the battery performance, the battery charger will recommence charging or move to the next stage.
8	Recondition (High Voltage Repair)	The recondition phase applies maximum voltage to maximise battery condition and further repair and clean battery plates. This may be required following significant discharge, for batteries with uneven cell capacity or, to alleviate acid stratification when calcium batteries are left discharged for more than a couple of days. NOTE: The battery charger will assess the condition of the battery and may not perform this function.
9	Maintain	The battery charger monitors the battery voltage and recommences the charge sequence when the voltage drops to 12.8V (or 6.4V)

DECLARATION OF CONFORMITY - UKCA

**UK
CA**

Clarke[®]
INTERNATIONAL

Hemnoll Street, Epping, Essex CM16 4LG

DECLARATION OF CONFORMITY

This is an important document and should be retained.

We hereby declare that this product(s) complies with the following statutory requirement(s):

Electromagnetic Compatibility Regulations 2016

Electrical Equipment (Safety) Regulations 2016

The Restriction of the Use of Certain Hazardous Substances in Electrical and Electronic Equipment Regulations 2012

The following standards have been applied to the product(s):

EN 55014-1:2006 +A1:2009 +A2:2011, EN 55014-2:2015, EN 61000-3-2:2014, EN 61000-3-3:2013,

EN 60335-2-29:2004+A2:2010, EN 60335-1:2012 +A11:2014 + A13:2017, EN 62233:2008,

IEC 62321-2:2013, IEC 62321-1:2013, IEC 62321-3-1:2013, IEC 62321-5:2013,

IEC 62321-4:2013+A1:2017, IEC 62321-7-1:2015, IEC 62321-7-2:2017.

The technical documentation required to demonstrate that the product(s) meet(s) the requirement(s) of the aforementioned legislation has been compiled and is available for inspection by the relevant enforcement authorities.

The UKCA mark was first applied in: 2021

Product Description: 6/12V intelligent battery charger 4/8A
Model number(s): IBC8
Serial / batch Number: N/A
Date of Issue: 12/07/2021

Signed:

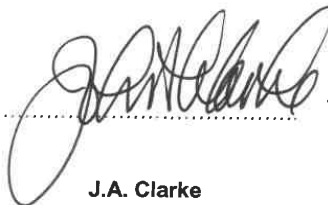

J.A. Clarke
Director

DECLARATION OF CONFORMITY - CE



Clarke[®]
INTERNATIONAL

Fitzwilliam Hall, Fitzwilliam Place, Dublin 2

DECLARATION OF CONFORMITY

This is an important document and should be retained.

We hereby declare that this product(s) complies with the following directive(s):

- 2014/30/EU Electromagnetic Compatibility Directive.*
- 2014/35/EU Low Voltage Equipment Directive.*
- 2011/65/EU Restriction of Hazardous substances (Amendment EU 2015/863).*

The following standards have been applied to the product(s):

- EN 55014-1:2006 +A1:2009 +A2:2011, EN 55014-2:2015, EN 61000-3-2:2014, EN 61000-3-3:2013,*
- EN 60335-2-29:2004+A2:2010, EN 60335-1:2012 +A11:2014 + A13:2017, EN 62233:2008,*
- IEC 62321-2:2013, IEC 62321-1:2013, IEC 62321-3-1:2013, IEC 62321-5:2013,*
- IEC 62321-4:2013+A1:2017, IEC 62321-7-1:2015, IEC 62321-7-2:2017.*

The technical documentation required to demonstrate that the product(s) meet(s) the requirement(s) of the aforementioned directive(s) has been compiled and is available for inspection by the relevant enforcement authorities.

The CE mark was first applied in: 2021

Product Description: 6/12V intelligent battery charger 4/8A
Model number(s): IBC8
Serial / batch Number: N/A
Date of Issue: 12/07/2021

Signed:

J.A. Clarke
Director

A SELECTION FROM THE VAST RANGE OF

Clarke®

QUALITY PRODUCTS



AIR COMPRESSORS
From DIY to industrial, Plus air tools, spray guns and accessories.

GENERATORS
Prime duty or emergency standby for business, home and leisure.

POWER WASHERS
Hot and cold, electric and engine driven - we have what you need

WELDERS
Mig, Arc, Tig and Spot. From DIY to auto/industrial.

METALWORKING
Drills, grinders and saws for DIY and professional use.

WOODWORKING
Saws, sanders, lathes, mortisers and dust extraction.

HYDRAULICS
Cranes, body repair kits, transmission jacks for all types of workshop use.

WATER PUMPS
Submersible, electric and engine driven for DIY, agriculture and industry.

POWERTOOLS
Angle grinders, cordless drill sets, saws and sanders.

STARTERS/CHARGERS
All sizes for car and commercial use.



PARTS & SERVICE: 0208 988 7400

Parts Enquiries
Parts@clarkeinternational.com

Servicing & Technical Enquiries
Service@clarkeinternational.com

SALES: UK 01992 565333 or Export 00 44 (0)1992 565335

Clarke INTERNATIONAL Hemnall Street, Epping, Essex CM16 4LG
www.clarkeinternational.com